

Technical details

Operating pressure	1 ... 10 bar	
Temperature range	-30°C ... +100°C	
Max. stroke	1000 mm	
Materials	Body:	Al (anodized)
	Guide rod:	steel hard chrome plated (bronze bearing) steel, tempered (ball bearings)
	Bearing:	sintered bronze (bronze bearing) steel (ball bearings)
	Seals:	NBR

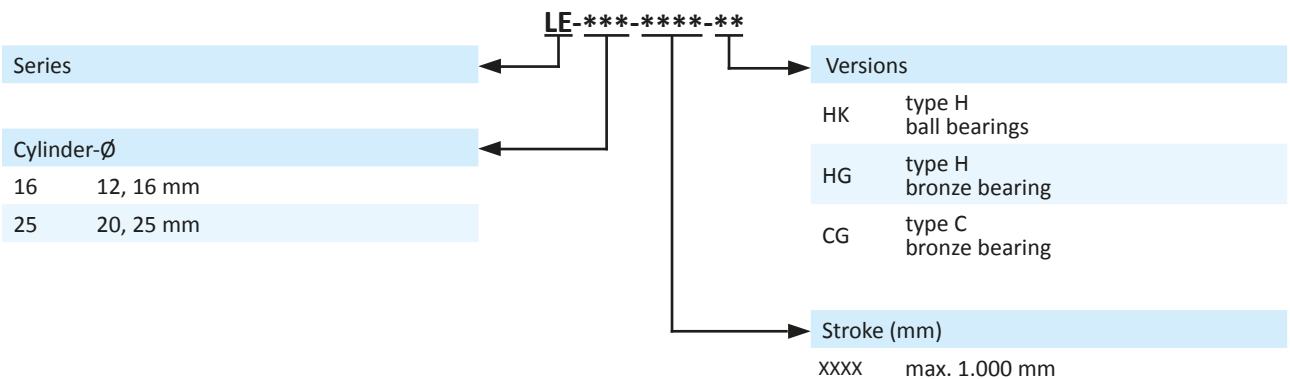

Linear guide for mini cylinder in accordance with ISO 6432.

Order code

Technical information

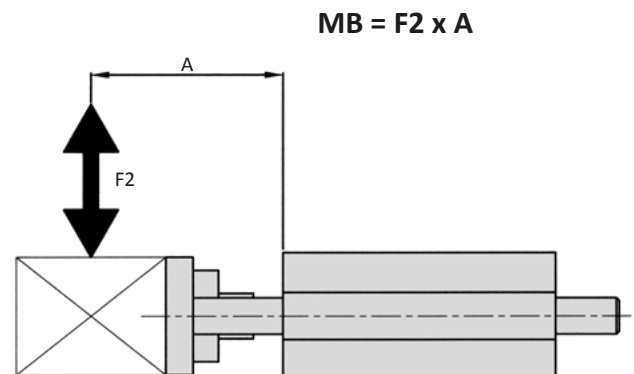
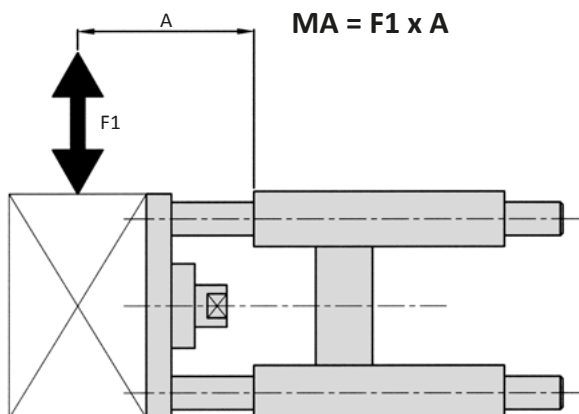
Version	Ø (mm)	16	25
CG	max. load MA (Nm)	6	13
	max. load MB (Nm)	5	12
HG	max. load MA (Nm)	6.5	19
	max. load MB (Nm)	5.8	17
HK	max. load MA (Nm)	9	11
	max. load MB (Nm)	8	10



Series LE

Linear guides

Dimensions type CG

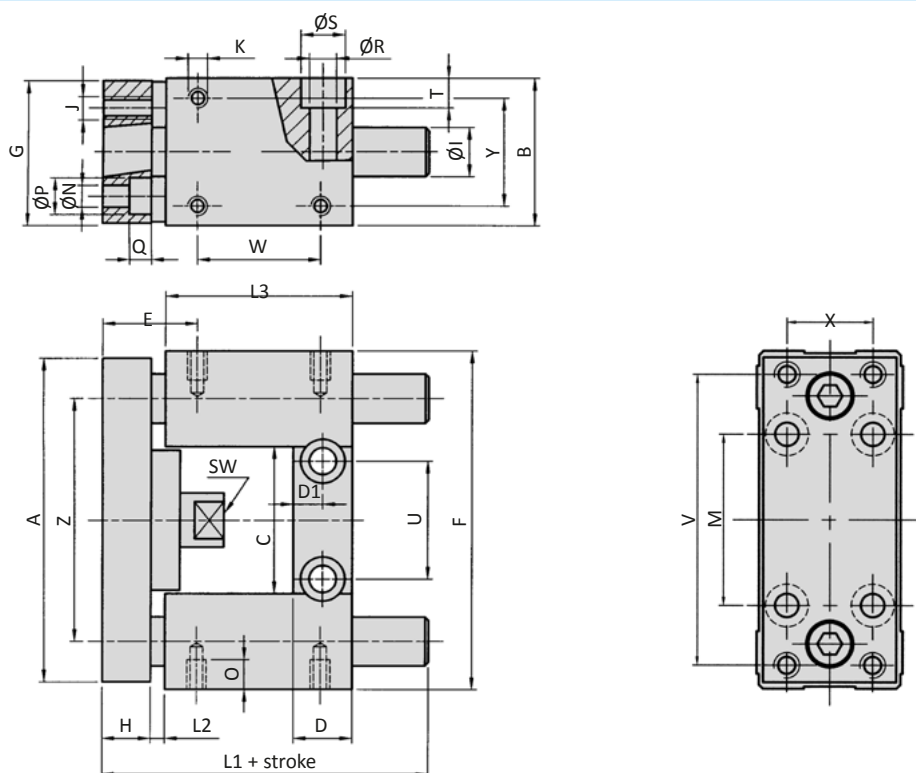

Ø	A	B	C	D	D1	E	F	G	H	Ø I	J	K	L1	L2	L3
16	66	30	30	12	6	19.5	69	29	10	10	M4	M4	66.5	3	38
25	78	34	37	17	8.5	21.75	79	32	12	12	M5	M6	83	3	48

Ø	M	Ø N	O	Ø P	Q	Ø R	Ø S	SW	T	U	V	W	X	Y	Z
16	32	4.5	6	7.5	4.5	5.5	9	8	6	24	58	25	18	22	49.5
25	38	5.5	9	10	7.5	6.5	11	12	7	38	68	32.5	20	23	58

Ø (mm)		16	25
Weight (kg)	0 mm stroke	0.30	0.50
	each 100 mm stroke	0.12	0.18

Dimensions type HG, HK

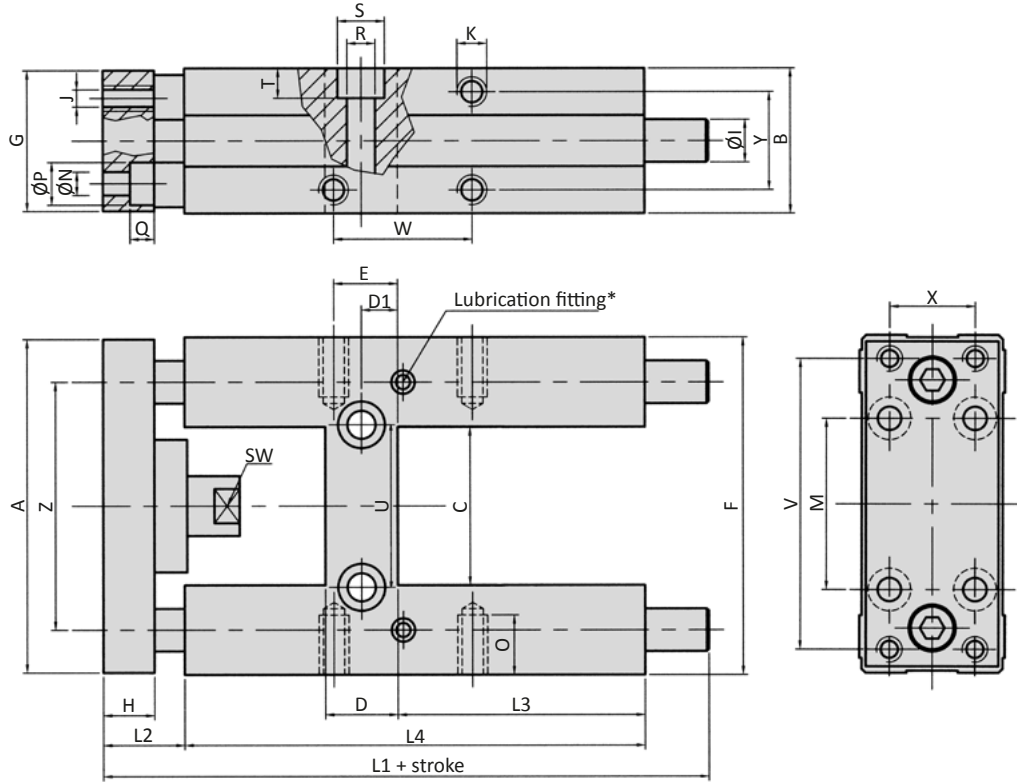

*only type HK

Ø	A	B	C	D	D1	E	F	G	H	Ø I	Ø I*	J	K	L1	L2	L3
16	66	30	30	12	6	8	69	29	10	10	8	M4	M4	123	32	46
25	78	34	37	17	8.5	15	79	32	12	12	10	M5	M6	165	15	58

* VersionHK

Ø	L4	M	Ø N	O	Ø P	Q	Ø R	Ø S	SW	T	U	V	W	X	Y	Z
16	68	32	4.5	6	8	6	5.5	9	8	5.5	24	58	18	18	22	49.5
25	108	38	5.5	9	10	9	6.5	11	12	6.5	38	68	32.5	20	23	58

Ø (mm)		16	25
Weight	0 mm stroke	0.40	0.90
Weight	HG (kg) each 100 mm stroke	0.12	0.18
Weight	0 mm stroke	0.36	0.84
Weight	HK (kg) each 100 mm stroke	0.08	0.12