

PMM-C

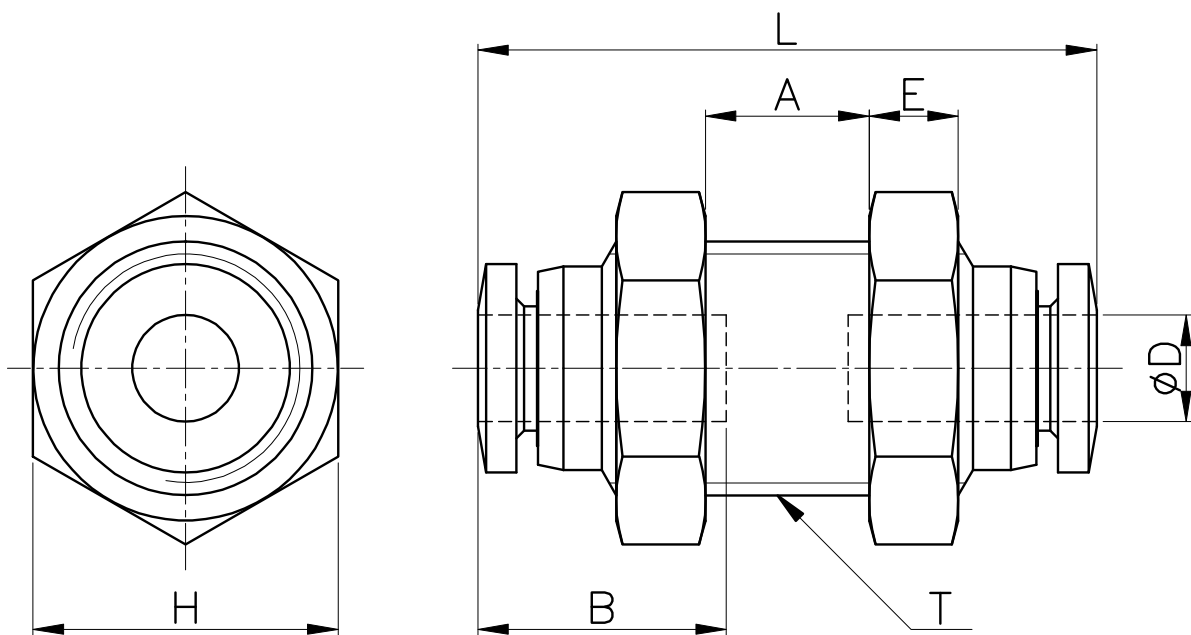

MODEL	øD	T	L	E	A	B	H (Hex)	ORIFICE	WEIGHT (g)	BOX(EA)
PMM 03C	3	M8*0.75p	23.4	3.0	7.1	11.2	10	2.0	6.0	100
PMM 04C	4	M10*1.0p	24.3	3.5	6.5	11.7	12	3.0	10.0	100
PMM 06C	6	M12*1.0p	26.9	4.0	8.0	12.7	14	5.0	14.0	100