

PLL-G

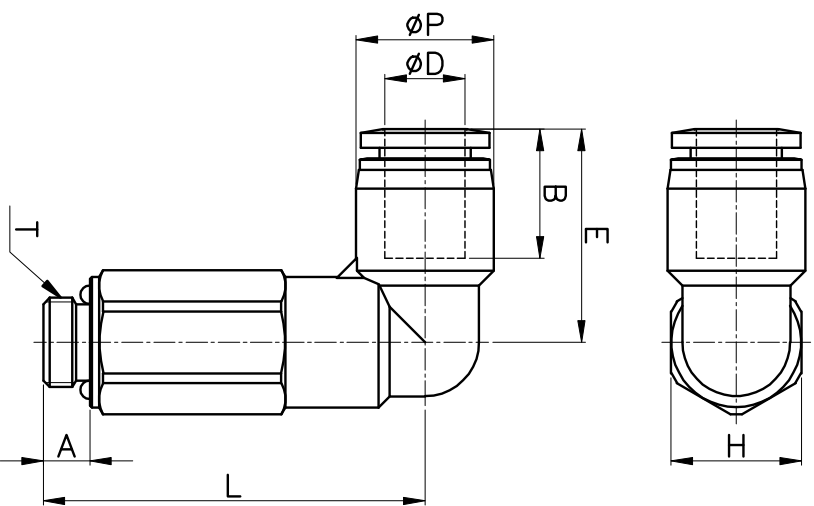

MODEL	ØD	ØP	T	L	E	A	B	H ^H (Hex)	ORIFICE	WEIGHT (g)	BOX(EA)
PLL 04-G01	4	10.5	G 1/8	33.5	18.5	5.0	14.8	14	3.0	27.0	50
			G 1/4	35.5		17		40.0			
PLL 04-G02	4	10.5	G 3/8	37.0	18.5	6.5	14.8	20	3.0	52.0	50
			G 1/8	37.5		14		30.0			
PLL 06-G01	6	12.5	G 1/4	39.5	20.3	6.5	16.4	17	4.0	44.0	50
			G 3/8	39.0		20		56.0			
PLL 08-G01	8	14.8	G 1/8	41.0	22.9	5.0	18.3	14	6.0	36.0	50
			G 1/4	43.0		17		47.0			
PLL 08-G02	8	14.8	G 3/8	42.5	22.9	6.5	18.3	20	6.0	62.0	25
			G 1/2	44.0		24		94.0			
PLL 10-G01	10	17.5	G 1/8	44.5	24.6	5.0	20.2	17	6.0	59.0	25
			G 1/4	46.5		17		65.0			
PLL 10-G02	10	17.5	G 3/8	46.0	24.6	6.5	20.2	20	6.0	73.0	25
			G 1/2	47.5		24		102.0			
PLL 12-G02	12	20.5	G 1/4	52.4	28.7	6.5	22.9	19	8.0	83.0	25
			G 3/8	51.9		20		84.0			
PLL 12-G03	12	20.5	G 1/2	53.4	28.7	8.0	22.9	24	10.0	118.0	25
			G 3/8	65.3		24		145.0			
PLL 16-G03	16	25.5	G 1/2	66.8	32.8	8.0	24.1	24	10.0	145.0	15
			G 3/8	65.3		24		145.0			
PLL 16-G04	16	25.5	G 1/2	66.8	32.8	8.0	24.1	24	13.0	145.0	15