

PH

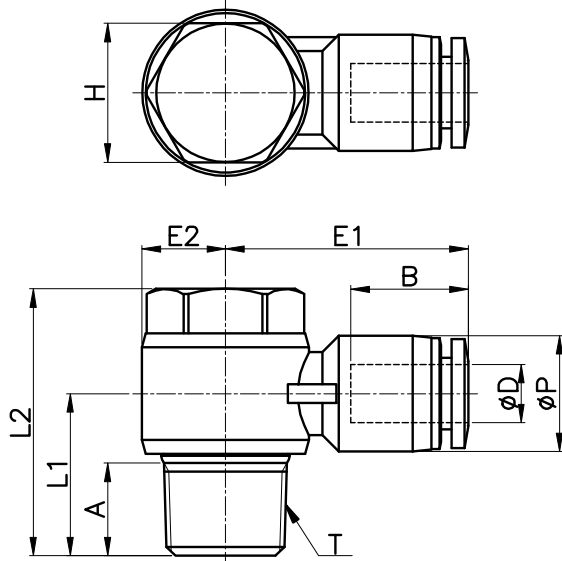

MODEL	øD	øP	T	L1	L2	E1	E2	A	B	H (Hex)	ORIFICE	WEIGHT (g)	BOX(EA)
PH 03-M5	3	7.8	M5*0.8p	9.6	18.2	16.6	5.0	3.6	11.3	8	2.0	7.0	100
PH 04-M5	4	10.5	M5*0.8p	10.3	18.2	20.2	5.0	3.6	14.8	8	2.0	8.0	50
PH 04-M6			M6*1.0p	14.1	20.7	20.2	5.0	4.1		8	2.5	9.0	50
PH 04-01			R 1/8	14.9	25.5	23.3	7.0	8.0	15.3	11	3.0	15.0	50
PH 04-02			R 1/4	17.4	28.8	25.3	9.0	10.0		15	3.0	27.0	50
PH 06-M5	6	12.5	M5*0.8p	11.4	18.2	22.7	5.0	3.6	16.4	8	2.0	9.0	50
PH 06-M6			M6*1.0p	13.0	20.7	22.7	5.0	4.1		8	3.0	10.0	50
PH 06-01			R 1/8	14.9	25.5	24.2	7.0	8.0		11	4.5	16.0	50
PH 06-02			R 1/4	17.4	28.8	26.2	9.0	10.0		15	5.0	27.0	50
PH 06-03			R 3/8	19.9	32.7	27.7	11.0	11.0		19	5.0	48.0	25
PH 06-04			R 1/2	24.0	38.7	30.7	14.0	14.0		24	5.0	74.0	25
PH 08-01	8	14.8	R 1/8	16.0	25.5	25.9	7.0	8.0	18.3	11	5.0	17.0	50
PH 08-02			R 1/4	18.2	28.8	27.9	9.0	10.0		15	6.6	28.0	50
PH 08-03			R 3/8	19.9	32.7	28.9	11.0	11.0		19	6.0	50.0	25
PH 08-04			R 1/2	24.0	38.7	31.8	14.0	14.0		24	6.5	77.0	25
PH 10-01	10	17.5	R 1/8	17.5	25.5	28.1	7.0	8.0	19.7	11	5.0	17.0	25
PH 10-02			R 1/4	19.7	28.8	29.9	9.0	10.0		15	6.4	32.0	25
PH 10-03			R 3/8	21.2	32.7	31.0	11.2	11.0		19	8.2	51.0	25
PH 10-04			R 1/2	24.0	38.7	33.4	14.0	14.0		24	8.0	78.0	20
PH 12-02	12	20.5	R 1/4	21.2	28.8	33.3	9.0	10.0	22.4	15	7.0	35.0	25
PH 12-03			R 3/8	22.0	32.7	33.7	11.5	11.0	21.9	19	9.6	53.0	25
PH 12-04			R 1/2	25.5	38.7	36.1	14.0	14.0		24	9.5	82.0	20