

CVPF-G

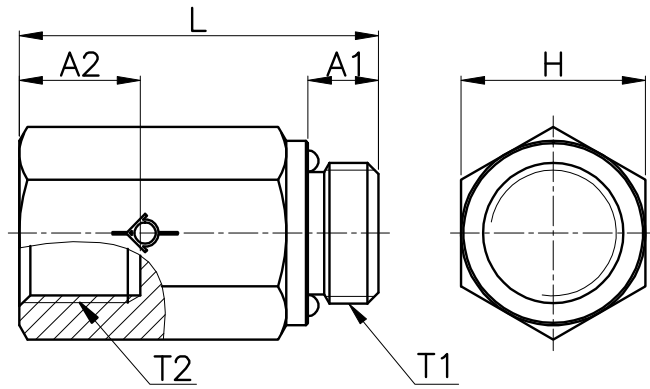

| MODEL | T1 | T2 | L | A1 | A2 | H (Hex) | WEIGHT (g) | BOX(EA) |
|--------------|-------|-------|------|-----|------|------------|---------------|---------|
| CVPF G01-G01 | G 1/8 | G 1/8 | 27.6 | 5.0 | 8.5 | 14 | 23.0 | 100 |
| CVPF G02-G02 | G 1/4 | G 1/4 | 33.3 | 6.5 | 11.0 | 17 | 39.0 | 50 |
| CVPF G03-G03 | G 3/8 | G 3/8 | 50.5 | 6.5 | 13.0 | 22 | 102.0 | 25 |
| CVPF G04-G04 | G 1/2 | G 1/2 | 56.7 | 8.0 | 15.0 | 24 | 121.0 | 25 |